

## USE AND INSTALLATION HANDBOOK

### SIMPLEX-UP

CONTROL PANEL FOR 1 ELECTRIC PUMP WITH CURRENT CONTROL.

## SIMPLEX-UP



# INDEX

1. **Warnings**  
page.....3
2. **Overview**  
page .....4
3. **Handling**  
page .....4
4. **Application and working limits**  
page .....5
5. **Operation**  
page .....6
6. **Installation**  
pages.....7-8
7. **Electrical connection**  
pages.....9-10
8. **Level sensor ( emptying / filling S/R)**  
page.....11
9. **Regulation and calibration**  
pages.....12-13
10. **Stop of the pump**  
page .....13
11. **Lights and push-buttons**  
page .....14
12. **Maintenance**  
page .....14
13. **Waste disposal**  
page .....15
14. **Warranty**  
page .....15
15. **Spare parts**  
page .....15
16. **Conformity declaration**  
page .....16
17. **connection diagrams**  
pages.....17 - 18 -19 - 20

# 1. WARNINGS

The following symbols, accompanied by the words: "Danger", "Warning", indicate the potential hazard resulting from failure to observe the associated warning, as specified below:



**DANGER  
RISK OF ELECTRIC  
SHOCK**

Failure to observe this warning may result in electric shock



**DANGER**

Failure to observe this warning may cause personal injury and/or damage to property



**WARNING**

Failure to observe this warning may cause damage to the pump, the unit or the system

- **CAUTION:**  
Make sure the pumps are fully primed before you start them.
- **CAUTION:**  
The control panel must be connected by a qualified electrician in compliance with the electrical regulations in force.
- **CAUTION:**  
The electric pump or the motor and the panel must be connected to an efficient grounding system in compliance with the electrical regulations locally in force.
- **CAUTION:**  
Ground the unit before carrying out any other operation.
- **CAUTION:**  
The electric pump or the motor can start up automatically.
- **CAUTION:**  
As a general rule, always disconnect the power supply before proceeding to carry out any operation on the electrical or mechanical components of the unit or system.

## 2. OVERVIEW

The purpose of this manual is to provide the necessary information for the proper installation, use and maintenance of SIMPLEX-UP. The user should read this manual before operating the unit. Improper use may cause damage to the machine and lead to the forfeiture of the warranty coverage. Always specify the model identification code and the construction number when requesting technical information or spare parts from our Sales and Service department. The instruction and warnings given below concern the standard version; refer to the sale contract documentation for modifications and special version characteristics. For instructions, situations and events not considered in this manual or in the sale documents, please contact our customer service.

Our units must be installed in sheltered, well-ventilated, non-hazardous environments and must be used at a maximum temperature of +40°C and minimum of -5°C.

## 3. HANDLING



**DANGER**



**WARNING**

the panel must be handled with care, as falls and knocks can cause damage without any visible external signs.

If for any reason the unit is not installed and starter immediately after it has reached its destination it must be stored properly. The external packaging and the separately packed accessories must remain intact, and the whole must be protected from the weather, especially from freezing temperatures, and from any knocks or falls.

**PRELIMINARY INSPECTION:** after you have removed the external packaging, visually inspect the control panel to make sure it has suffered no damage during shipping.

If any damage is visible, inform a FOURGROUP dealer as soon as possible, no later than **5 days** from the delivery date.

## 4. APPLICATION AND WORKING LIMITS



**DANGER  
RISK OF ELECTRIC  
SHOCK**



**WARNING**

*SIMPLEX-UP is designed for controlling 1 motor or electric pump used in pressurization systems or in applications for emptying wells or water tanks with multi-contact float switches.*

**FOURGROUP S.r.l. shall not be liable for any damage caused or suffered by the unit as a result of its unauthorised or improper use.**

### TECHNICAL FEATURES :

- Electronic control panel;
- Power Supply 1~50/60Hz 230V +/- 10% (SIMPLEX-UP-M – Single-Phase);
- Power Supply 3~50/60Hz 400V +/- 10% (SIMPLEX-UP-T – Three-phase);
- Control input from NO contact (float/pressure switch);
- Alarm control input from NO contact (float/pressure switch);
- Control input with three minimum level sensors;
- Input for motor winding thermal protection;
- Sensors suitable for use with not flammable conductive fluids (not included);
- Incorporated selector for sensor operation in "Filling/Emptying" mode (dip-switch 1 and 2);
- Incorporated sensor sensitivity adjustment;
- Push buttons for operating motor in "Automatic-Off-Manual" modes;
- "Mains power on" LED;
- "Alarm" LED for min/max water level;
- "Motor on" LED;
- "Motor protection enabled" LED;
- "Automatic" LED (this is on the AUTOMATIC push-button);
- Restore protection button;
- Adjustable motor protection (Motor Current Trimmer: 2 <> 22A or 20 <> 44A);
- Protection activation time: 5";
- Incorporated dip-switch for overriding the "Motor cut-out" (dip-switch 4);
- Internal "Sensors alarm" cut off dip-switch (dip-switch 3);
- Internal "ammetric alarm cut-in delay" cut off switch (jumper ESC. TIM. TA);
- Motor protection fuses;
- Auxiliary protection fuse;
- Alarm output with switching NO-C-NC contacts, capacity 16A 250V (resistive load);
- Single-phase version adapted for the insertion of a capacitor (not included);
- Main circuit-breaker with door lock;
- Output with cable clamps;
- ABS box;
- Protection IP55;
- Ambient temperature: -5/+40 °C;
- Relative humidity 50% at 40 °C (not condensed);

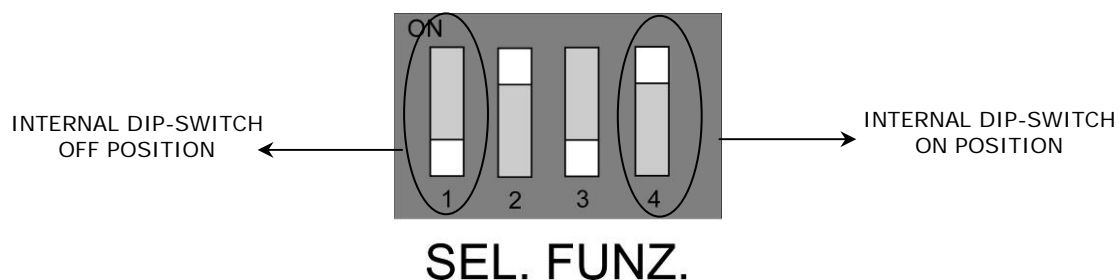

**Do not use the product in environments where dust, acids, corrosive and/or flammable gases etc. are present.**

## 5. STANDARD OPERATION



**DANGER**  
**RISK OF ELECTRIC**  
**SHOCK**



**DANGER**



**WARNING**

The “**Mains power on**” LED comes on to indicate that the board is working properly.

The motor can be governed directly by the operator with man present (**Manual**) or by remote signals (**Automatic**) by means of the “**Automatic – Off – Manual**” buttons; (when the automatic button is pushed the related LED above the button lights and the control panel is ready to receive remote signals from the sensors and floats).

The motor works in **Automatic** by means of the **G1** command that can be any clean contact (e.g. float or pressure switch).

The min/max level is controlled by the sensor commands based on how the internal

**DIP-SWITCH 1 AND 2** are set:

**1=ON 2=OFF → Emptying**

**1=OFF 2=ON → Filling**

**ATTENTION: it is dangerous to set both the dip-switches to on or off position: in first case the motor runs ever without level sensor deactivation; in second case the motor doesn't start with any level.**

The sensor control input can also be used for the Start/Stop operations, closing the **G1** control with a wire jumper and respectively connecting two controls (e.g. floats) between “**Com-Min (Stop float)**” and “**Com-Max (Start float)**” in place of the 3 sensors.

**N.B.: When using this configuration the sensors alarm must be overridden by SETTING THE DIP-SWITCH 3 TO OFF POSITION, otherwise the “level alarm” LED for the min/max level will come on (based on the E/F setting) and the alarm output will be activated.**

**3=ON → Level sensor alarm enabled**

**3=OFF → Level sensor alarm disabled**

In the event the “**Min/Max level**” sensors are tripped, the motor stops, the “**LEVEL ALARM**” light comes on and the Alarm output relay is tripped.

**The sensitivity of the level sensors can be adjusted by means of the “SENS. SONDE” (SENSOR SENSITIVITY) Trimmer, based on the conductivity of the liquid in which they are immersed. By increasing the sensors sensitivity, correct functioning is also possible in the presence of liquid with poor conductivity.**

The green pilot light “**MOTOR ON**” indicates the functioning of the motor.

If the Overload protection is tripped, the motor stops and the red “**PROTECTION ON**” and “**LEVEL ALARM**” LED lights on. **Push RESET to reset the alarm;**

Check for the cause of the malfunction before restoring the motor to operation

**The motor overload protection can be overridden by set the dip-switch 4:**

**4=ON → Amperometric protection enabled: “PROTECTION ON” and “LEVEL ALARM” leds lighting + motor stop + alarm output**

**4=OFF → Amperometric protection disabled: “PROTECTION ON” led lighting without motor stop and without alarm output. In this manner the “PROTECTION ON” alarm LED is activated but the motor continues to run and the alarm output does not activate.**

The amperometric protection tripping current can be adjusted by means of the “**CORRENTE MOTORE**” (MOTOR CURRENT) Trimmer, based on the rated absorption of the motor; the adjustment can be made from a minimum of 2A to a maximum of 22A. (To determine  $I_{max}$  read  $I_n$  writing on chart model of the membrane).

The cut-in delay time is fixed at 5 seconds and can be overridden during setting by bridging the “**ESC.TIM.TA**” Jumper;

### GENERAL NOTES :

During the calibration for Over-Load Protection, start the motor 2-3 times to check the correct operating.

## 6a. INSTALLATION



**DANGER**  
**RISK OF ELECTRIC**  
**SHOCK**



**DANGER**



**WARNING**

### Line of supply current

Connect the unit at ground before carrying out any other operation.

The voltage input corresponds to the data written on the panel and on the pump.

( **400V**  $\pm$  10% 50/60Hz x **SIMPLEX-UP-T** )  
( **230V**  $\pm$  10% 50/60Hz x **SIMPLEX-UP-M** ).

Make sure that the power-supply-cable can bear the nominal current and connect it to the terminals of the general switch of the control panel.

If the cables are exposed, they must be appropriately protected.

The line must be protected with a differential circuit breaker measured in accordance with the regulations locally in force.

### Line of motor power supply

Connect the unit at ground before carrying out any other operation.

The voltage input corresponds to the data written on the motor.

(**400V**  $\pm$  10% 50/60Hz **three-phase**)  
(**230V**  $\pm$  10% 50/60Hz **single-phase**).

Doing some starting make sure that the motor respects the right direction of rotation usually indicated by an arrow printed on the motor.

### Line of external control

It is possible to control the motor in "**Automatic**" using a free voltage contact normally open as a float switch or a pressure switch.

It is a line in very low voltage and not a power line. Connect anyway with the control panel switched off and with the circuit breaker disconnected.

## 6b. INSTALLATION

- TO FIX THE CABLES IN THEIR TERMINALS USE A TOOL OF THE PROPER SIZE TO AVOID THE DAMAGING OF THE SCREWS OR OF THEIR SEAT. If use an electric screwier pay attention not to spoil the thread or the screws.
- FIX THE CONTROL PANEL TO A WALL AS IN PICTURE N.1 WITH SCREWS AND SCREW ANCHOR USING THE HOLES ARRANGED IN THE BOX OR THE FIXING BRACKET IF PRESENT.

AFTER THE FIXING, REMOVE EVERY PLASTIC OR METALLIC SURPLUS (ex. Pieces of copper of the cables or plastic shavings of the box) INSIDE THE BOX BEFORE SUPPLING POWER.

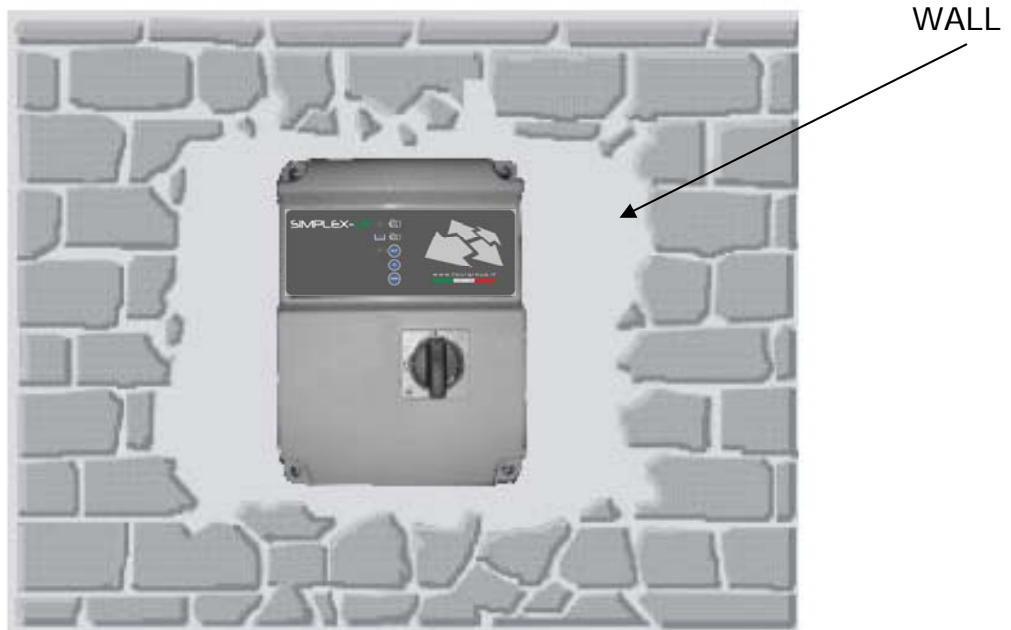

**Fig.1**

***N.B. : DO NOT INSTALL THE CONTROL PANEL CLOSE TO OBJECTS IN CONTACT WITH FLAMMABLE LIQUIDS, WATER OR GAS.***



# 7a. ELECTRICAL CONNECTION SIMPLEX-UP-T



**DANGER**  
RISK OF ELECTRIC  
SHOCK



**DANGER**



**WARNING**

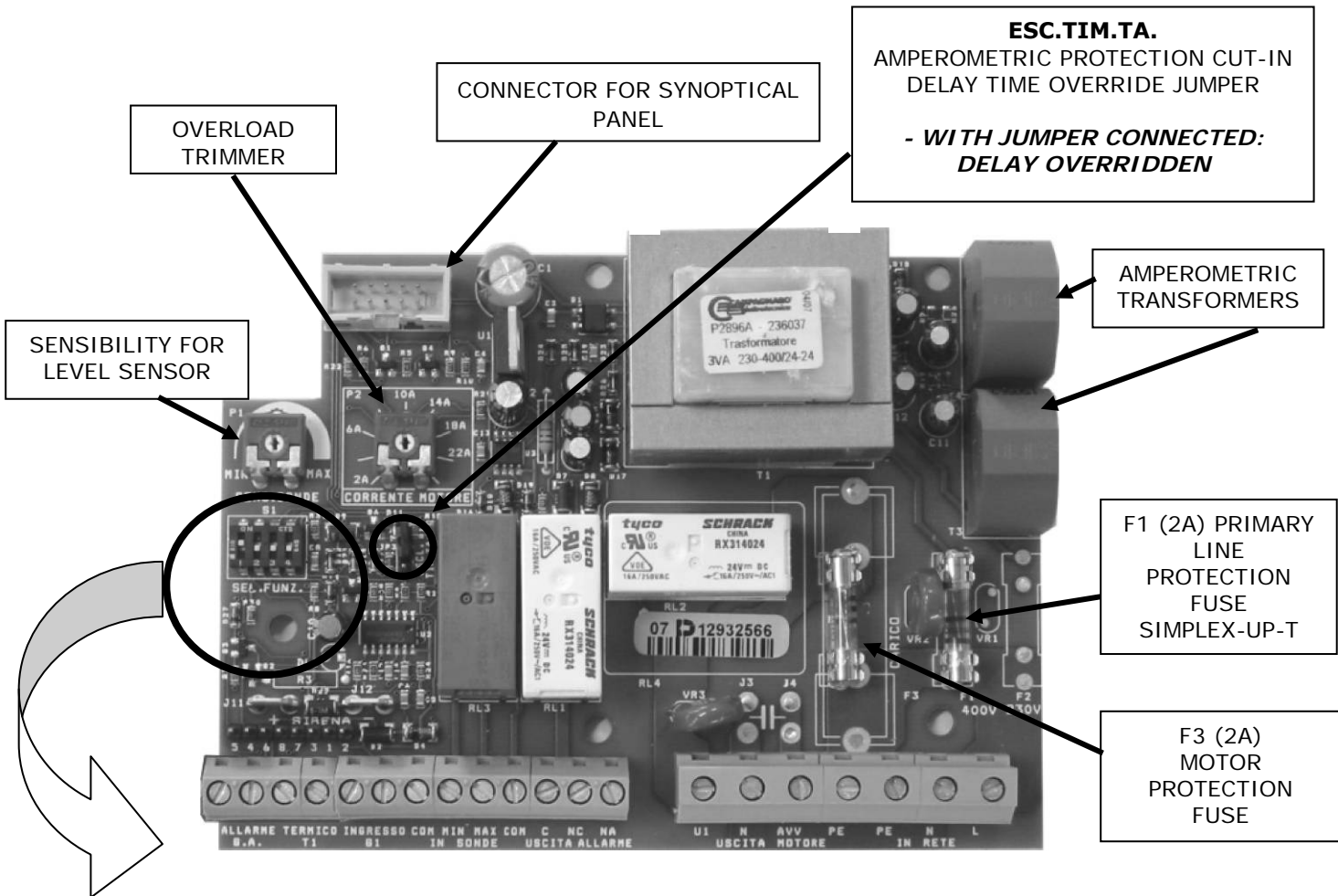

## DETAILS:

### INTERNAL DIP-SWITCHES:

**1=ON; 2=OFF -> EMPTYING ----->**

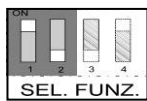

**1=OFF; 2=ON -> FILLING ----->**

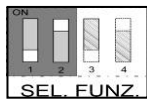

**3=OFF -> LEVEL ALARM DISABLED ----->**

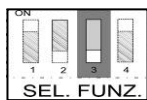

**3=ON -> LEVEL ALARM ENABLED ----->**

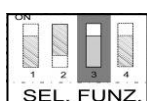

**4=OFF -> AMPEROMETRIC PROTECTION --> DISABLED**



**4=ON -> AMPEROMETRIC PROTECTION --> ENABLED**

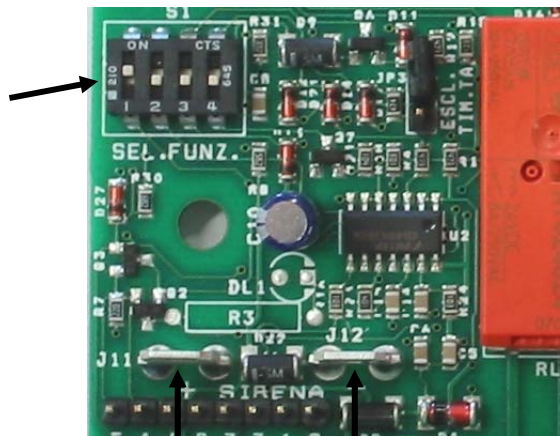
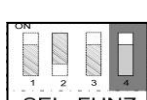

OUTPUT 12Vcc for SIREN only  
activated by high level float switch  
(ALLARME G.A.)

# 7 b. ELECTRICAL CONNECTION SIMPLEX-UP-M



**DANGER**  
RISK OF ELECTRIC SHOCK



**DANGER**



**WARNING**

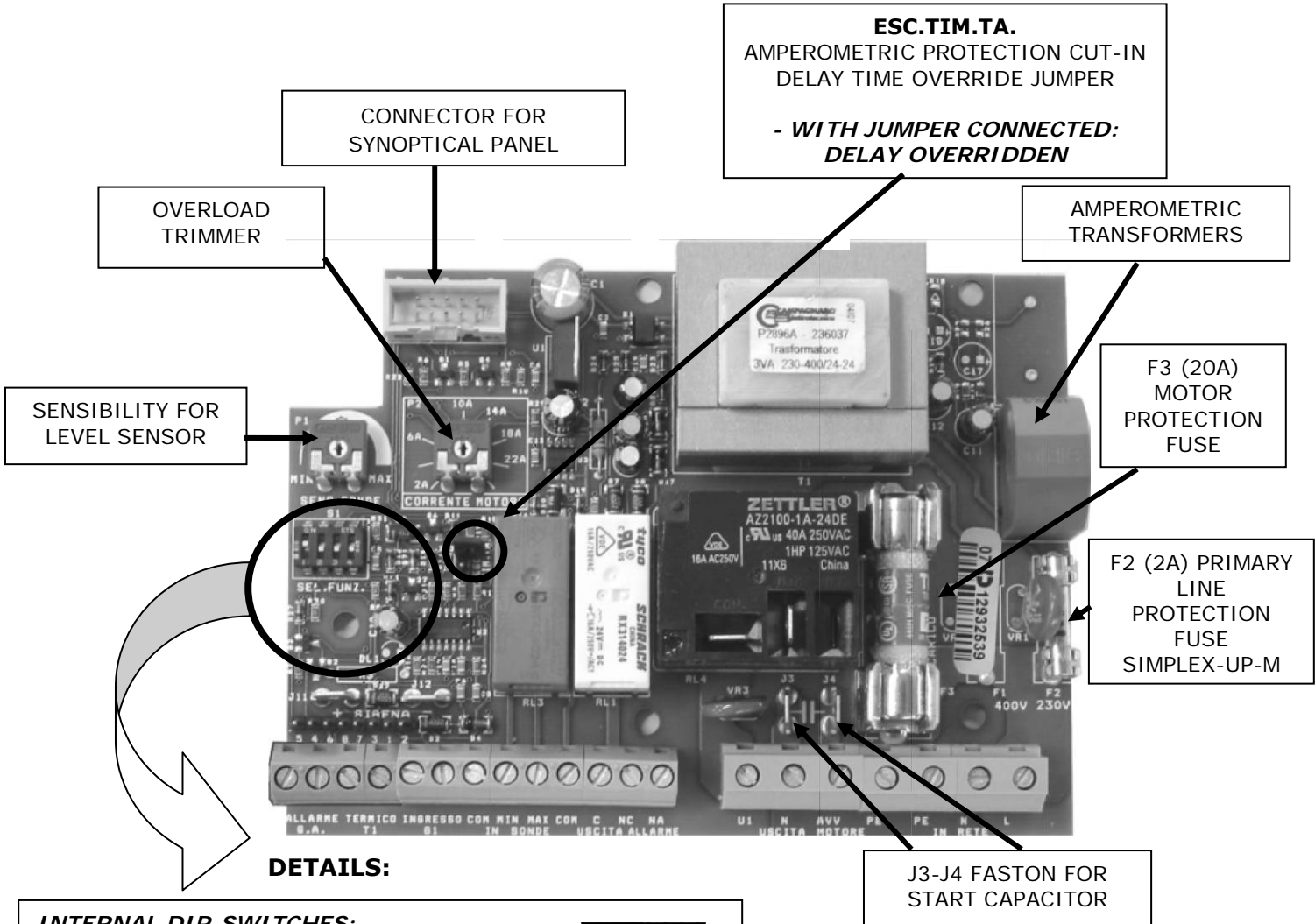

**INTERNAL DIP-SWITCHES:**

|  |  |
|--|--|
| <b>1=ON; 2=OFF -&gt; EMPTYING</b> ----->                   |  |
| <b>1=OFF; 2=ON -&gt; FILLING</b> ----->                    |  |
| <b>3=OFF -&gt; LEVEL ALARM DISABLED</b> ----->             |  |
| <b>3=ON -&gt; LEVEL ALARM ENABLED</b> ----->               |  |
| <b>4=OFF -&gt; AMPEROMETRIC PROTECTION --&gt; DISABLED</b> |  |
| <b>4=ON -&gt; AMPEROMETRIC PROTECTION --&gt; ENABLED</b>   |  |

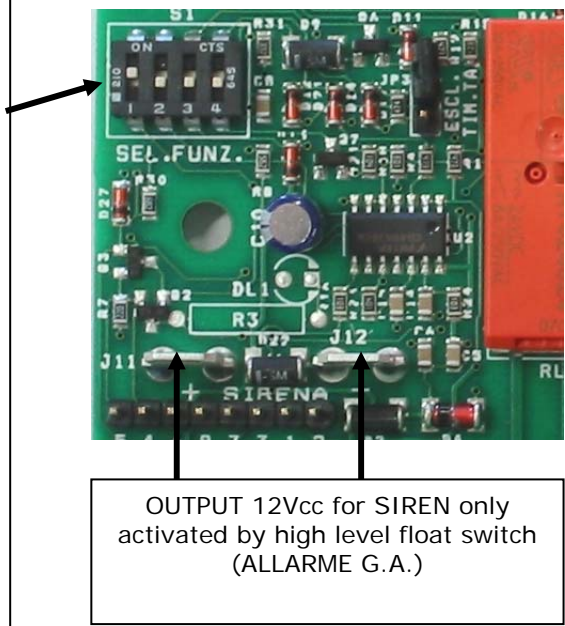

## 8. LEVEL SENSOR FUNCTION ( EMPTYING / FILLING )



**DANGER**  
**RISK OF ELECTRIC**  
**SHOCK**



**DANGER**



**WARNING**

You can select the type of operation with the sensors working in Emptying / Filling mode by set **dip-switches 1 and 2** on the card:

### EMPTYING :

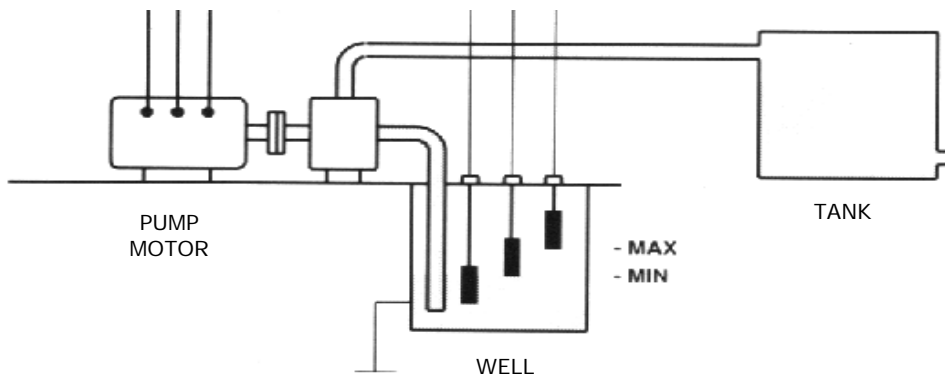

Set the dip-switches **1=ON** and **2=OFF**.

The control panel is enabled only when all the sensors are immersed in the fluid (**COM-MIN** and **COM-MAX** contacts closed). The motor is enabled by the closing of the G1 contact (float/pressure switch).

The motor is cut out by the sensors when the **COM-MIN** contact opens. The alarm output is also enabled.

### FILLING :

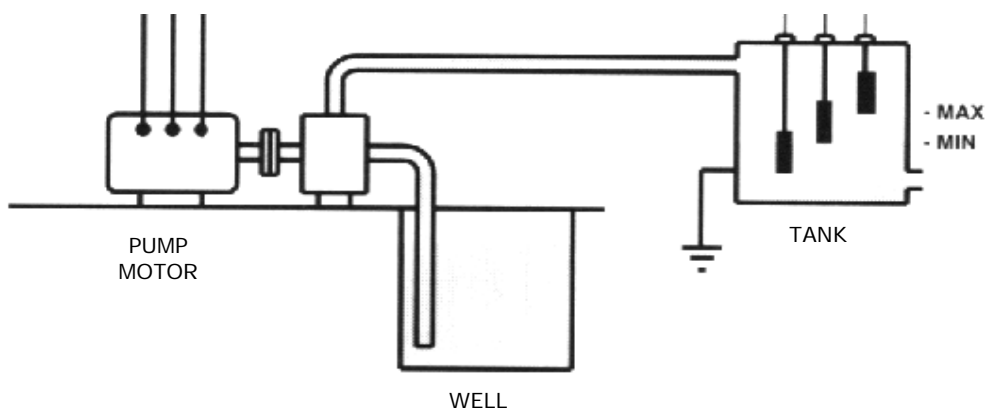

Set the dip-switches **1=OFF** and **2=ON**.

The motor is enabled when the two MIN and MAX sensors are not covered by the fluid (**COM-MAX** and **COM-MIN** contacts open).

The motor is enabled when the **G1** contact closes (float/pressure switch).

The motor is cut out by the sensors when the **COM-MAX** contact closes. The alarm output is also enabled.

## 9a. REGULATION AND CALIBRATION

Before the ignition the **"System of Motor Protection from Overload"** has to be calibrated setting the **Current Protection** on the internal regulator of the Board.

The **Protection Delay** is set at a fix time of **4 seconds**.

**During the calibration close the "ESC.TIN.TA" JUMPER to disable the delay protection;**

The **Regulator of Current Protection** depends on the value of calibration set on the board (MOTORS 2-22A, MOTORS 20-44A );

### EXAMPLE OF CALIBRATION FOR MOTORS FROM 2 to 22A

- Current Protection Regulator

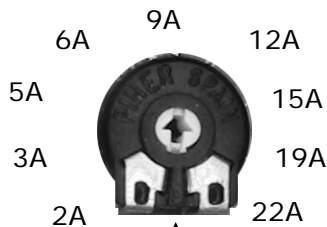

Set the current protection of the motor at a value superior of about 10-20% of the nominal current.

Example: for a motor with nominal electrical input of 10A set it at about 12A

Trimmer "CORRENTE"

### EXAMPLE OF CALIBRATION FOR MOTORS FROM 20 to 44A

- Current Protection Regulator

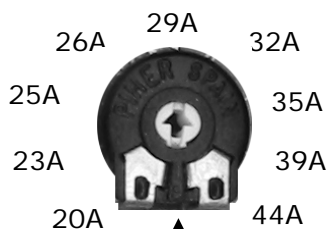

Set the current protection of the motor at a value superior of about 10-20% of the nominal current.

Example: for a motor with nominal electrical input of 30A set it at about 36A

Trimmer "CORRENTE"

**N.B.: When the setting is complete, reset the protection tripping current delay time by removing the "ESC.TIM.TA" JUMPER;**

## 9b. REGULATION AND CALIBRATION

EXAMPLE OF CURRENT PROTECTION FOR A THREE PHASE MOTOR:

Suppose that we want to set the Protection from Overload for a three phase motor of 5,5kW (7,5Hp) with a Nominal Supply Current of about **12 A**.

### CALIBRATION STEPS:

- Override the current protection cut-in delay time by **CONNECTING** the ESC.TIM.TA JUMPER, after motor start;
- Set the maximum value with the internal regulator on the "**Protection tripping current**" panel (turn clockwise)
- Turn the motor on and, with the "**Protection tripping current**" regulator, reduce until the red "Motor Protection" LED comes on and the motor stops; (THIS SHOULD CORRESPOND APPROXIMATELY TO THE RATED CURRENT... 12A);
- Increase the "Protection tripping current" adjustment by approximately 10-20% of the previously set value. (AT APPROX. 15a)
- Reset the Protection Cut-in Delay by **REMOVING** the ESC.TIM.TA JUMPER; (the delay is used to allow for the initial inrush currents);
- At this point the protection is set and the control panel can be set for the desired type of operation: EMPTYING – FILLING.

The Motor overload cut-out can be overridden by **SETTING** the internal **DIP-SWITCH 4 TO OFF POSITION (AMP. PROTECTION CUT-OUT OVERRIDEN)**:

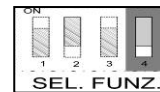

In this way the protection cut-in will be signalled by the "**Motor protection enabled**" light, but the motor will not be blocked.

## 10. STOP OF THE PUMP



### WARNING

The MOTOR can be switched off in the following ways:

- In "manual", the motor stops when the "MANUAL" button is released;
- In "automatic", the motor stops when the G1 switch is no longer enabled or when the level sensors, if used, give a max./min. level alarm based on how the dip-switches 1 and 2 has been set or by pushing the "0 – RESET" button;
- Turning the general switch with door interlock to "0".

## 11. LIGHTS and PUSH-BUTTONS ON THE FRONT-PANEL



INDICATES THAT THE MAIN POWER IS ON (**GREEN LIGHT**)



INDICATES THAT THE ALARM LEVEL IS ON ( **RED LIGHT**)

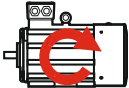

INDICATES THAT THE MOTOR IS RUNNING (**GREEN LIGH**)

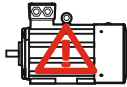

CONTEMPORARY LIGHTING INDICATES THAT THE OVERLOAD PROTECTION IS ON (**RED LIGHT**)



INDICATES THAT THE THERMAL PROTECTION OF WINDING IS TRIPPED (**RED LIGHT**)



KEEPING IT SWITCHED, THE MOTOR STARTS BY-PASSING EVERY ALARM; WHEN IT IS RELEASED THE MOTOR GET DISCONNECTED .



DISCONNECT THE MOTOR AND RESET THE WORKING PROTECTIONS



WHEN PUSHED, THE AUTOMATIC MODE IS ACTIVATED WHICH IS INDICATED BY THE GREEN LED; THE BOARD IS READY TO RECEIVE SIGNALS FROM THE FLOATS, PRESSURE SWITCHES OR SENSORS.

## 12. MAINTENANCE



**DANGER**  
**RISK OF ELECTRIC**  
**SHOCK**



**DANGER**



**WARNING**

SIMPLEX-UP does not require any routine maintenance provided that their working limits are observed. Any maintenance operations must be performed by qualified and experienced personnel, in compliance with the safety regulations in force.

### **DANGER!**

**Make sure that SIMPLEX-UP is disconnected from the power supply before performing any maintenance operations.**

## 13. WASTE DISPOSAL

After the control panel has been installed and started, the customer must provide for the appropriate elimination/disposal of the waste materials according to the legislation locally in force.

If the control panel or parts of it must be taken out of service and dismantled, follow local regulations regarding sorted waste disposal. Refer to the appropriate recycling centres.

**CAUTION:** Contamination of the environment with hazardous substances such as battery acid, fuel, oil, plastic, copper, etc., may cause serious damage to the environment and endanger people's health.

## 14. WARRANTY

Our products are guaranteed for a year from the date of commissioning; this applies only to products purchased from our offices or from our authorised retailers. The warranty does not extend beyond 15 months from the date of shipping. If the shipping documentation is missing, the date of manufacture is given in the code on the nameplate or fused into the interior of the terminal box. The warranty covers all manufacturing defects of material manufactured by us; it covers replacement and repair only, at our premises and by our staff, of the defective panel or part. The warranty does not provide for any claims by the customer. The warranty does not cover damage caused by faulty electrical connections, lack of adequate protection, incorrect assembly, incorrect use or any negligence in installing and operating the plant. The WARRANTY is also void in the following circumstances:

- damage due to corrosion or abrasion of any type or nature;
- malfunction due to improper installation;
- repair, disassembly or tampering by unauthorised persons;
- failure by the customer to pay due amounts.

The defective product must be returned to our factory carriage paid. We reserve the sole right to determine the cause of the defect and whether it is covered by the warranty or not. After the repair, the goods will be returned to the Customer carriage forward. WE DECLINE all liability for damages and injury caused by our products.

Fourgroup S.r.l. reserves the right to modify its products without notifications. Any controversy arising from the terms of this warranty shall be resolved in the Padua Court, even if payment is agreed by bank's draft.

For any further information, refer to the sales contract.

## 15. SPARE PARTS

Always state the exact model identification number and construction number when requesting technical information or spare parts from our sales and service centre.



Use only original spare parts when replacing any faulty components.



The use of unsuitable spare parts can cause malfunctions, personal injury and damage to property.

## 16. CONFORMITY DECLARATION

**FOURGROUP S.r.l.** with centre in Polverara via Enrico Fermi, 8 – Padova – Italy,  
declare that the products

### **SIMPLEX-UP-M , SIMPLEX-UP-T**

are in compliance with the following European directives and with the national directives of actuation :

- Machine 2006/42/CE
- European Directive 2006/95/CE
- Electromagnetic compatibility 2004/108/CE  
and the following technical rules:
- EN 61439-1, EN 61439-2, EN 55014-1, EN 55014-2, EN 61000-3-2,  
EN 61000-3-3

Polverara – Italy, 30/10/2014

LEGAL REPRESENTATIVE

(Grigoletto Per. Ind. Walter)





# 17a. CONNECTION DIAGRAMS FOR SIMPLEX-UP-M

## CONFIGURATION 1

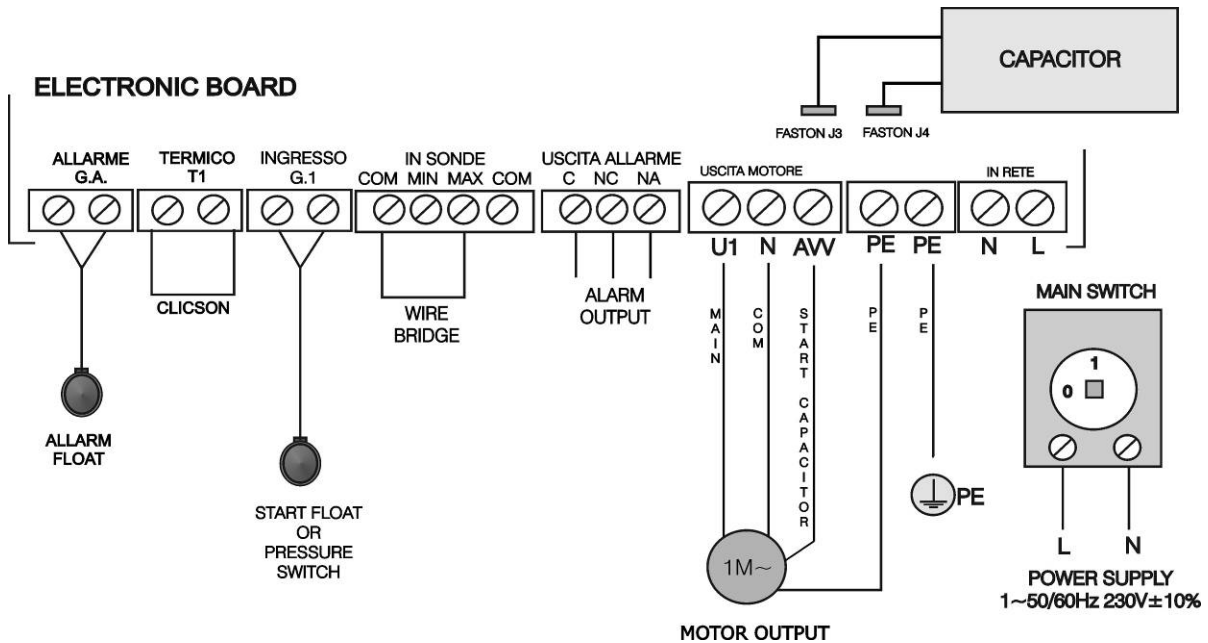

## CONFIGURATION 2 (NOT USE WITH DIRTY WATER)

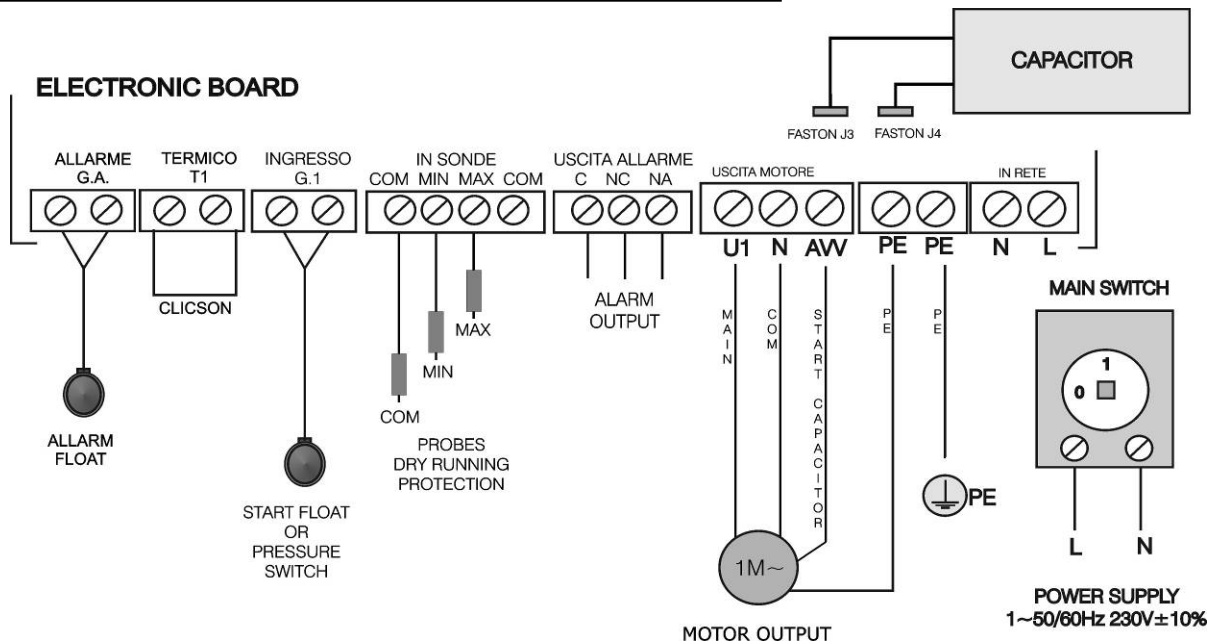

# 17b. CONNECTION DIAGRAMS FOR SIMPLEX-UP-M

## CONFIGURATION 3

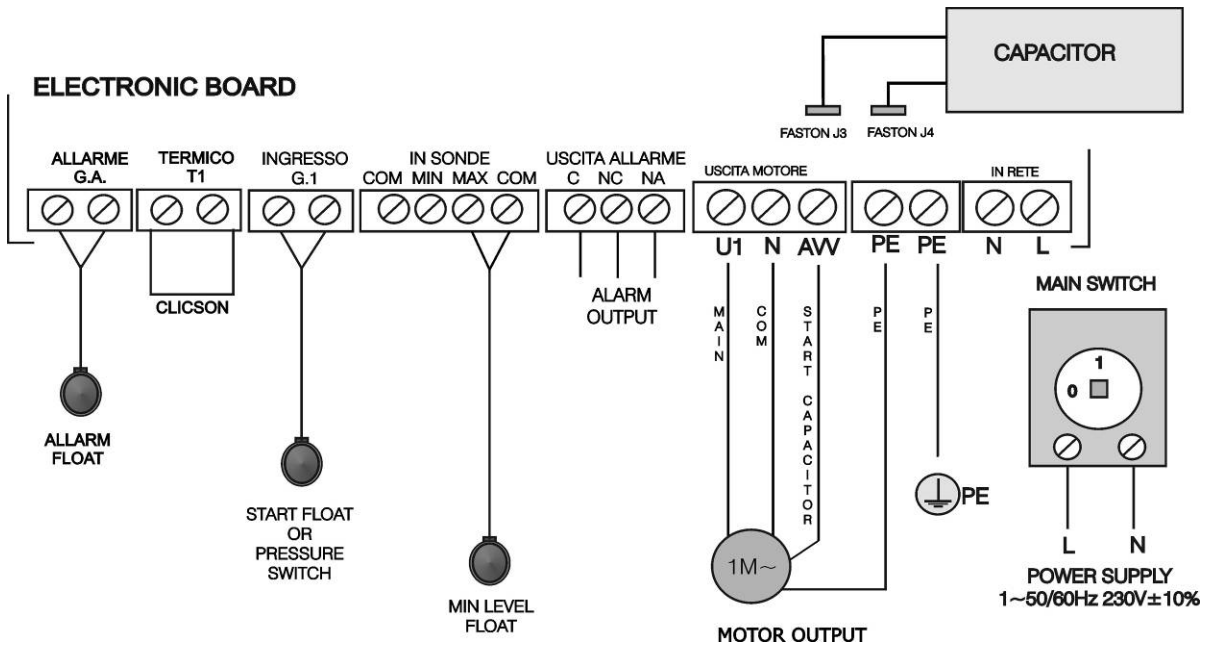

## CONFIGURATION 4

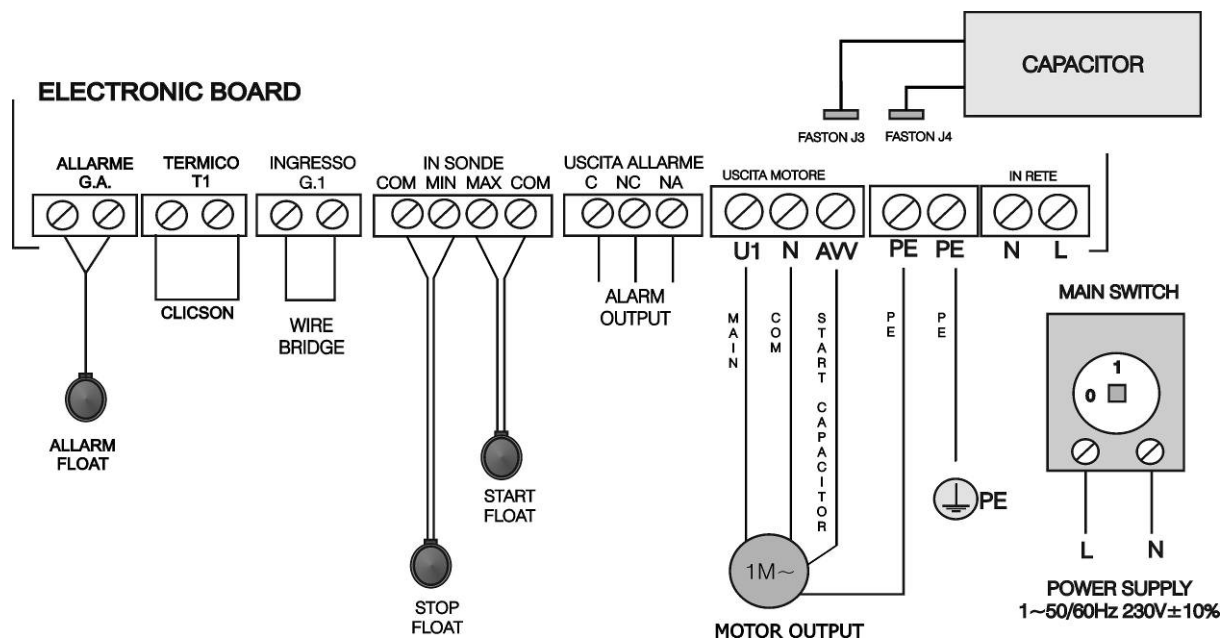

# 17c. CONNECTION DIAGRAMS FOR SIMPLEX-UP-T

## CONFIGURATION 1

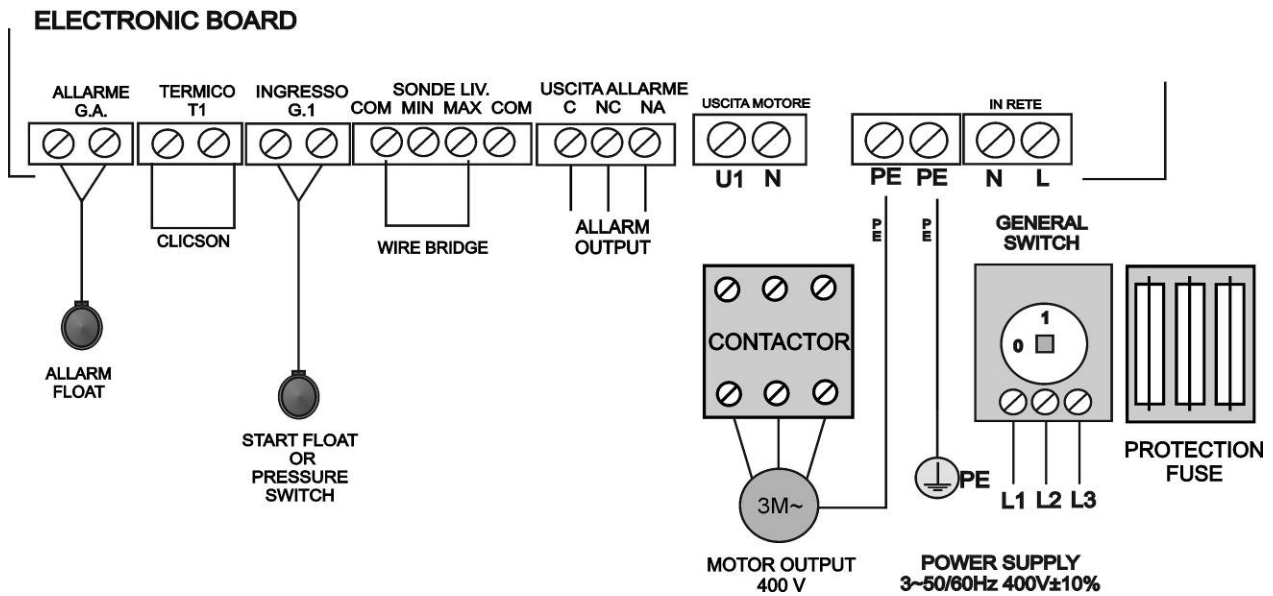

## CONFIGURATION 2 (NOT USE WITH DIRTY WATER)

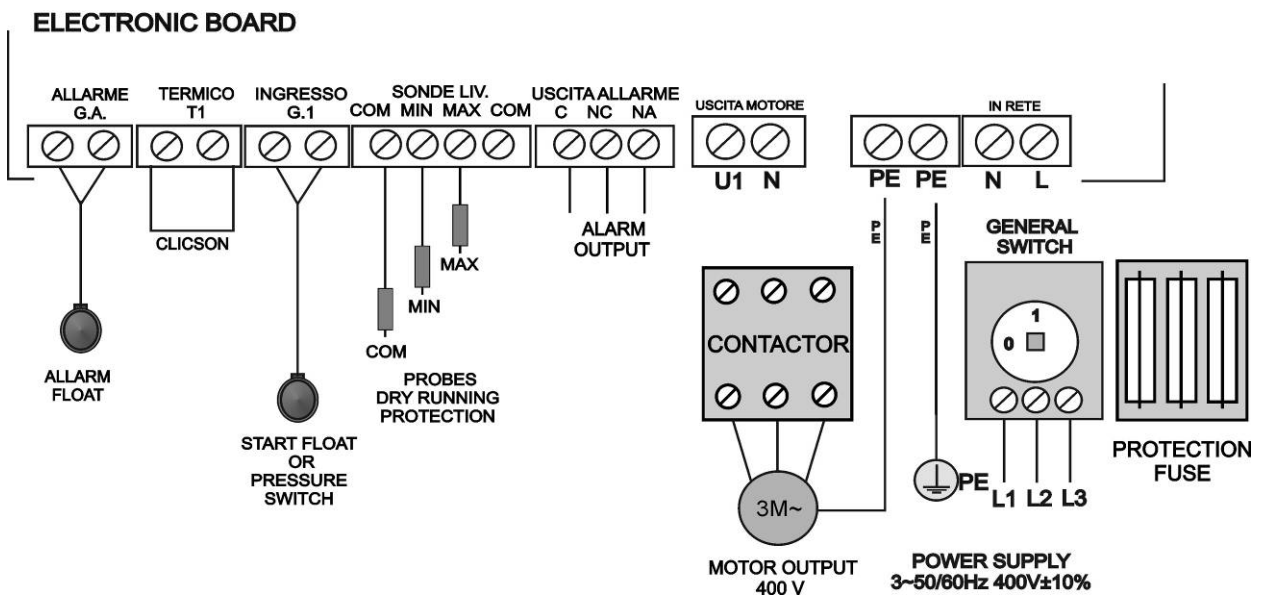

# 17d. CONNECTION DIAGRAMS FOR SIMPLEX-UP-T

## CONFIGURATION 3

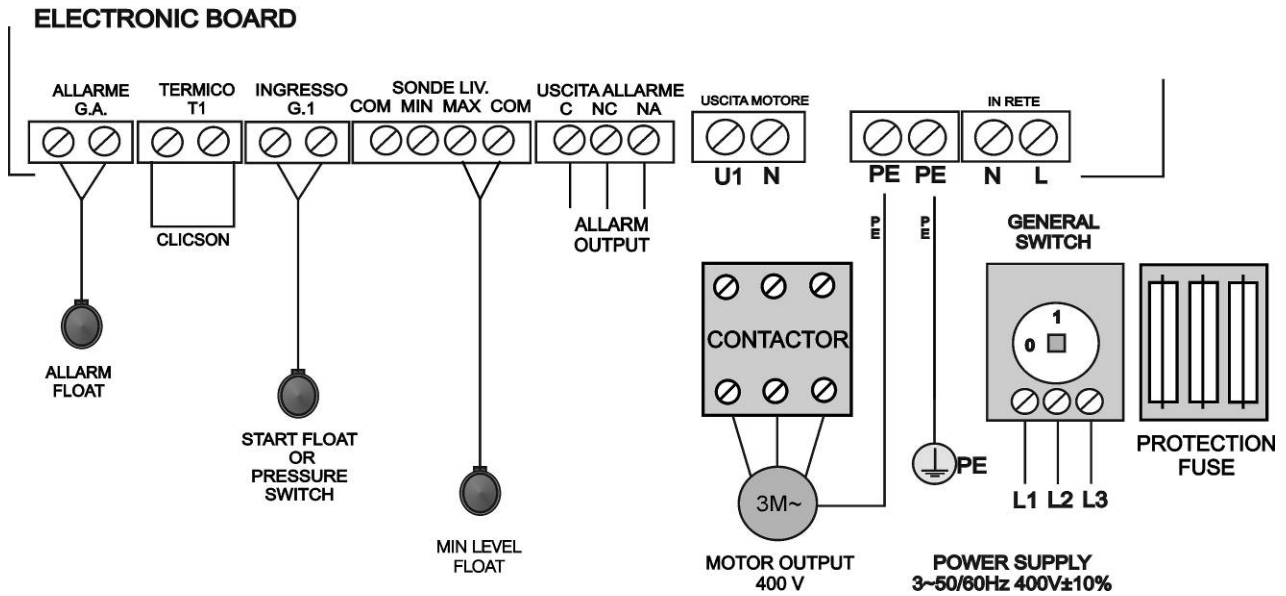

## CONFIGURATION 4

